



Community Advisory Committee Meeting

April 11, 2022



1. Welcome & Roll Call
2. Project Updates & Upcoming Meetings
3. Landscape Architecture Design
4. Small Business Support Programs & Business Working Group
5. Early Results from Muni Taxi/Bicycle/Transit Interaction Study
6. Open Discussion

Phase 1 - 100 % Design	October 8, 2021
Advertisement	October 13, 2021
Pre-bid Meeting	October 28, 2021
Bid Opening	December 1, 2021
Award Construction Contract	Spring 2022
Notice to Proceed (NTP)	Summer 2022
Construction Start	Fall 2022

Date: April 25, 2022

Time: 5:30 pm

- 35 new trees will be planted
- Proposed removal of 21 trees
 - 15 trees are in poor condition
 - 6 trees in conflict with infrastructure and utility placement

<https://sfpublicworks.org/calendar/4-25-2022-public-works-hearing>

Market Street: A Collaboration of Modern Design Masters

Date: April 26, 2022

Time: 12-1pm

Better Market Street team is partnering with California Preservation Foundation to provide a free virtual tour and panel discussion that highlights the cultural and historical significance of Market Street Redevelopment Plan

<https://californiapreservation.org/events/market-st-modern-sf/>

Landscape Architecture and Design Update

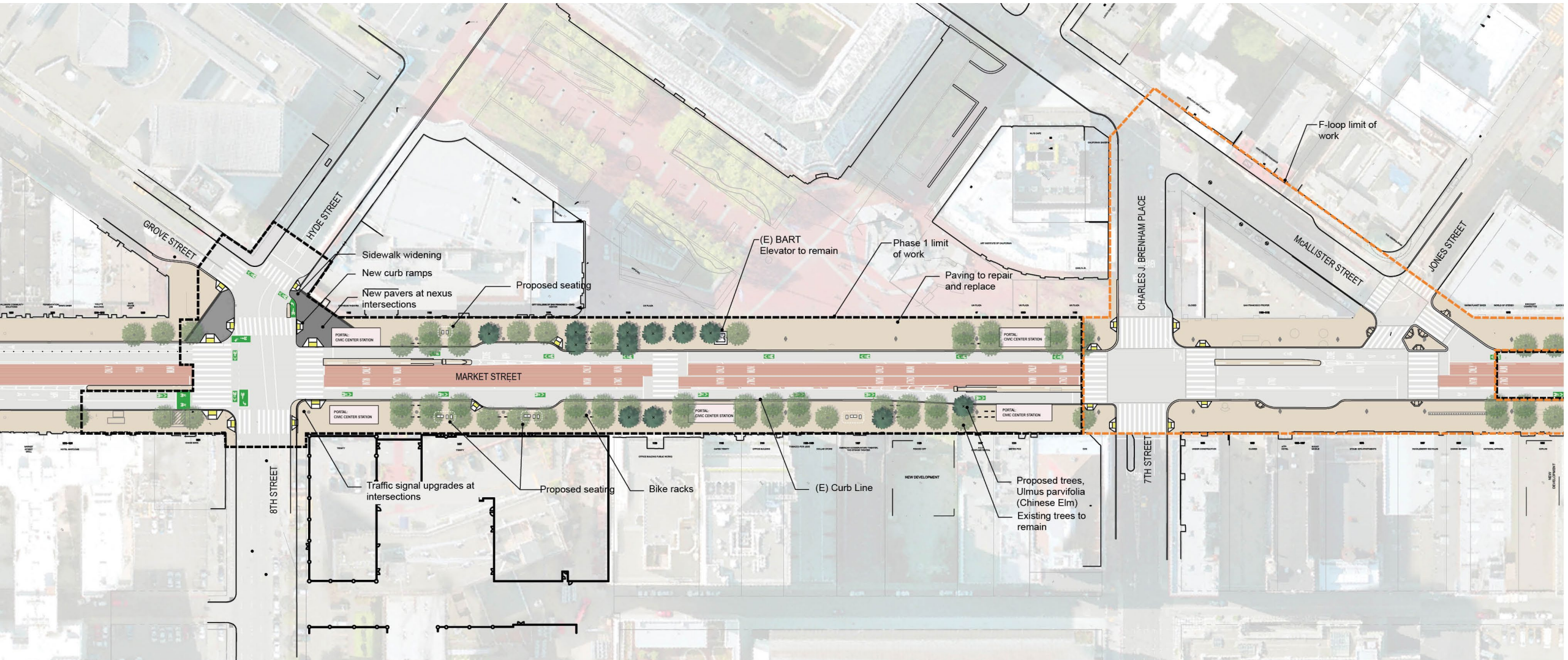

Landscape Architecture and Design Update

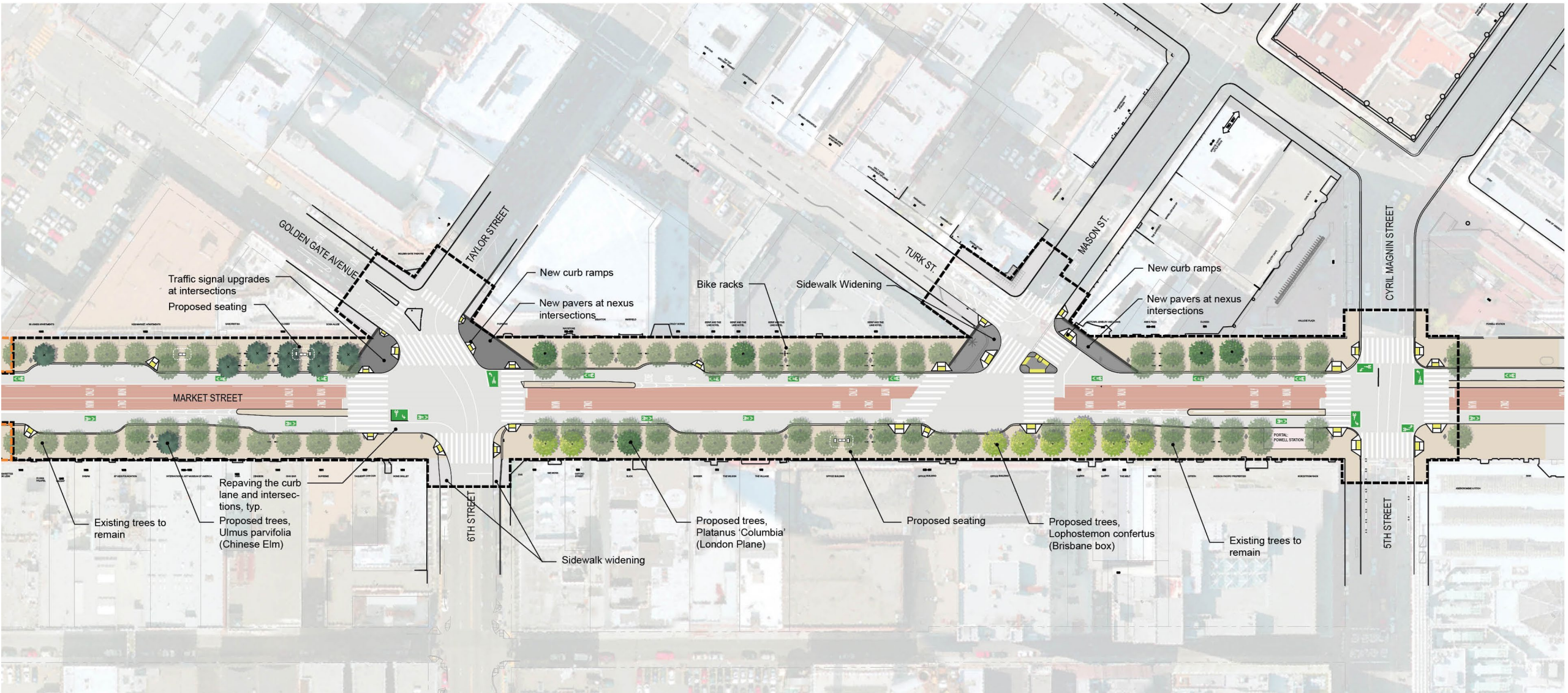



Platanus



Ulmus



Lophostemon

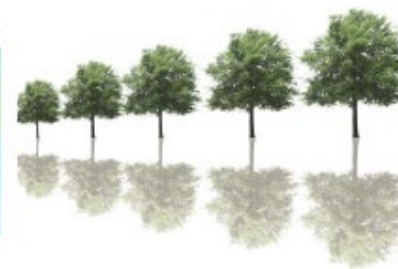
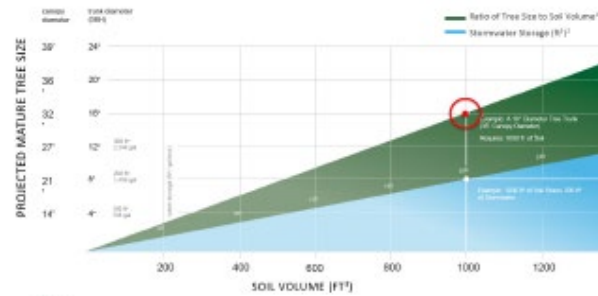



Concrete Pavers



Bike Racks

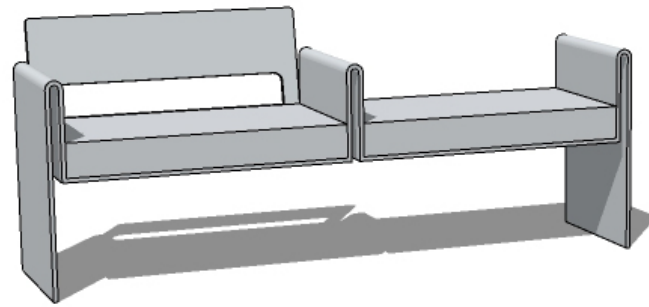

Seating

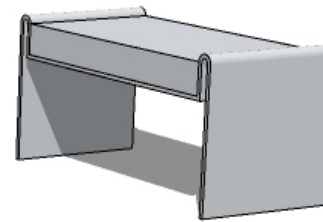

- **OEWD's Invest in Neighborhoods Initiative will serve as a business liaison and point of contact for business support services, like the Open for Business Program**
- **Open for Business Program provides direct marketing support for businesses in areas with active construction projects**
- **Participating merchants guide the program's direction, priorities and marketing tactics**
- **For more information, contact Jada Jackson: (415) 554-6477, jada.jackson@sfgov.org.**

- **Business Working Group will provide input on branding materials and other marketing efforts to promote small businesses in the corridor**
- **Consulting and providing feedback on the City's construction mitigation efforts**
- **Civic Edge is working with OEWD in surveying the small businesses along the corridor**

Comparing “MUNI TAXI ONLY” lanes (3rd-12th) with “MUNI ONLY” lanes (Main-3rd)

- 8 hours observations collected fall 2021
- 47 Muni operator surveys
- 142 taxi driver surveys



Vehicles/Hour Using Center Lanes



7

6

5

4

3

2

1

0

■ MUNI-ONLY LANE
(1ST IB AM + 2ND OB PM)

■ MUNI/TAXI LANE
(7TH IB AM + 5TH OB PM)

Private
(Includes TNCs)

Other Buses
(Shuttles/
School/Tour)

Commercial

Municipal
(Police/Fire/SFPW)

Taxis



- 7 of 235 (3%) observed Muni vehicles had minor delays approaching boarding islands – most due to 3+ Muni vehicles arriving during one signal cycle.
- No taxi pick-ups or drop-offs observed at boarding islands



Taxi Use of Center Lanes

- 48% observed taxis used center lane where permitted (7th IB AM; 5th OB PM)
- 78% observed taxis used center lane where prohibited (1st IB AM; 2nd OB PM)

Taxi Driver Survey - If there were no restrictions, how often would you drive in...

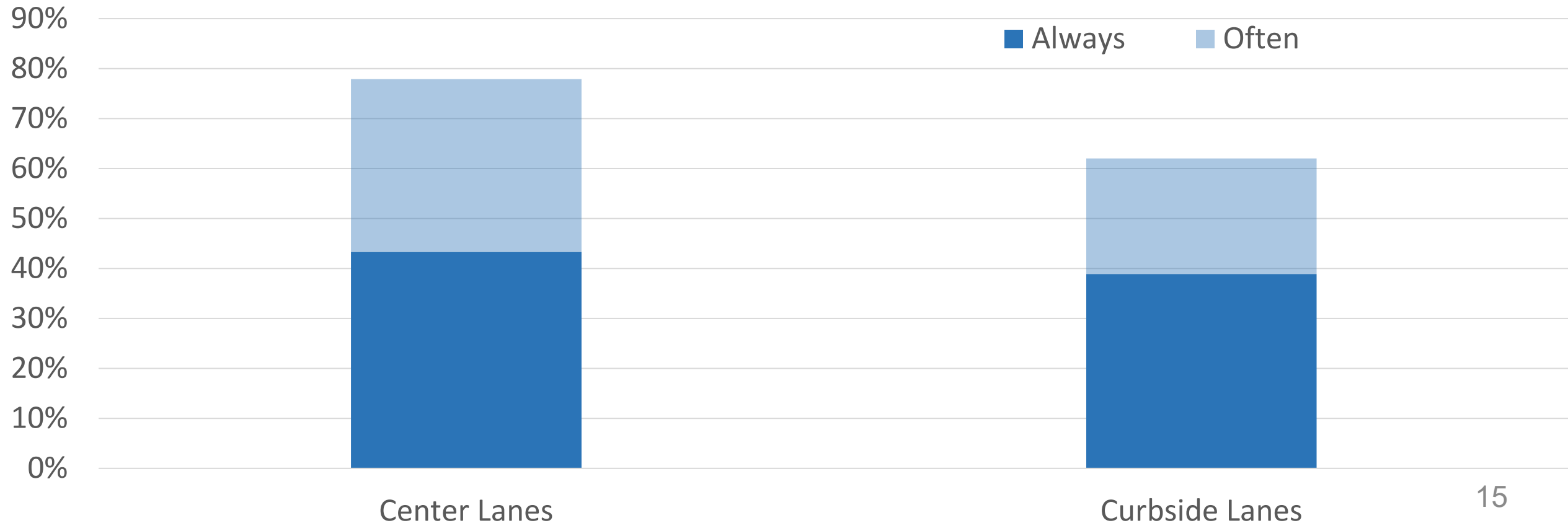

Taxi Driver Survey - Unsafe Interactions

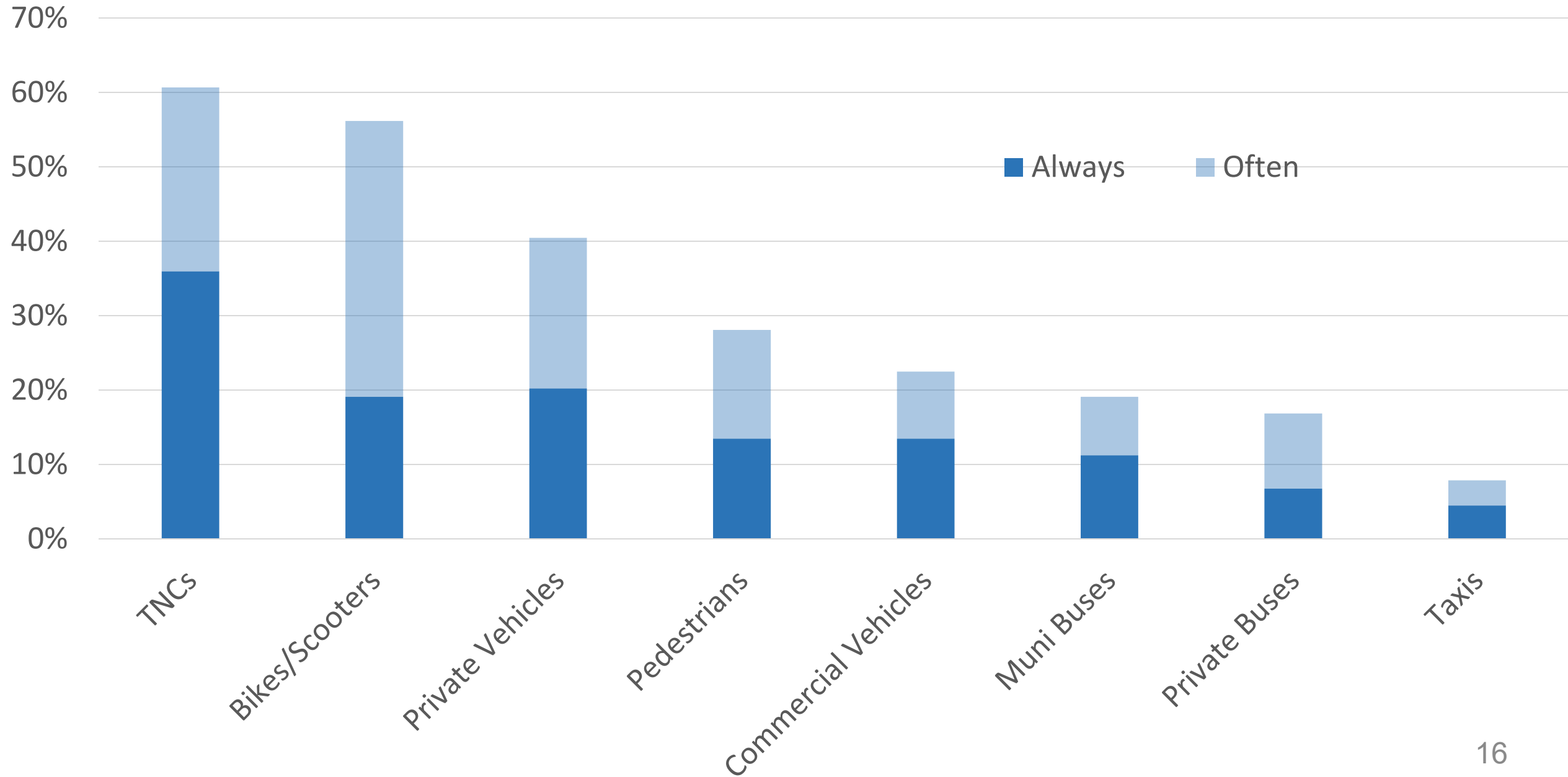

Taxi Driver Feedback on Muni-Only Lanes

- Confusing to customers who may believe taxis are prohibited from being on Market
- Challenges with curbside lanes being blocked, particularly IB at 1st
- Added delay for taxi trips



Muni Operator Feedback - Delays

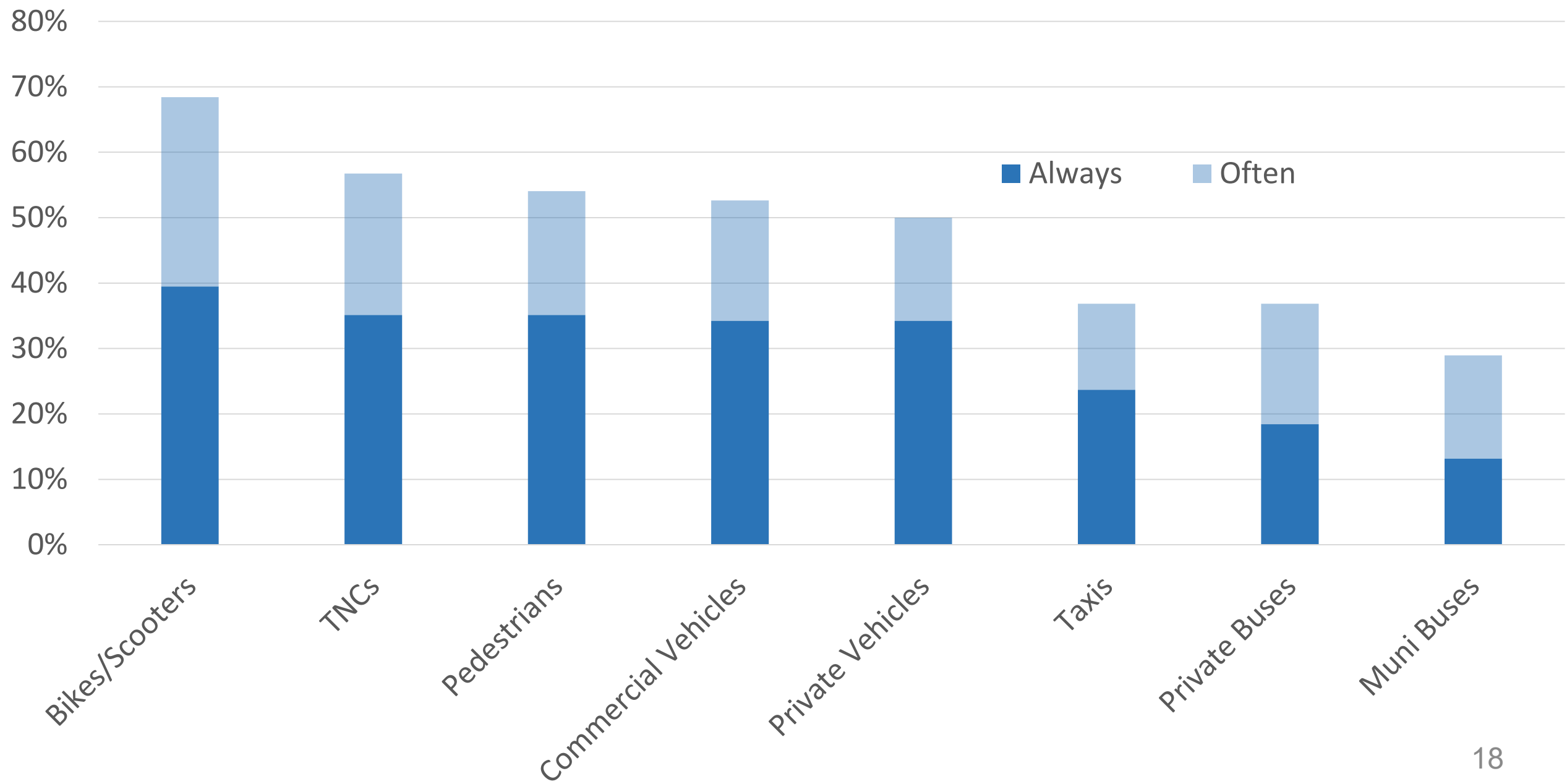

Muni Operator Feedback – Unsafe Interactions

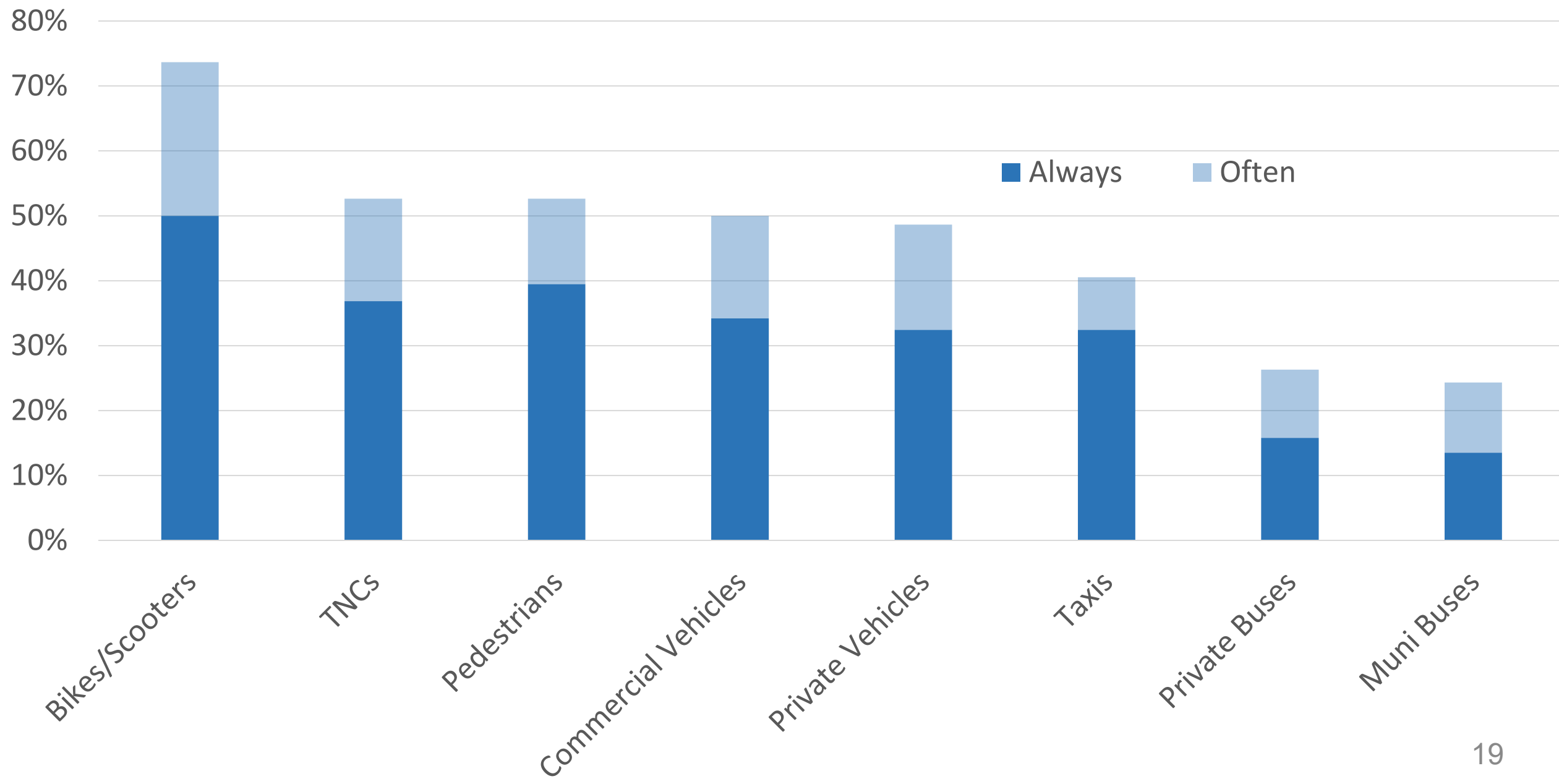

Better Market Street Phase 1



- **Five traffic signal upgrades**
- **Repave** curb lane and intersections, including crosswalks
- Construct ADA-compliant **curb ramps**
- Construct **four bulb outs** at Sixth, Hyde, and Mason/Turk
- **Replace sidewalks** at the corners
- **Streetscape improvements** including new trees, benches and bike racks

Utility work:

- **Install four catch basins** near 6th to improve drainage
- **Minimal sewer work** triggered by curb ramp and regrading work
- **Relocate one** low pressure fire hydrant for sidewalk widening
- **Minimal Auxiliary Water Supply System (AWSS)** work at Market/6th St triggered by bulb out
- **Minimal Overhead Contact System (OCS) work** triggered by joint OCS/signal poles